

---

---

# MANUAL

---

---

---

**1214-8**  
**1215-8**  
**1219-8**

**MultiMode™**  
**MOTOR CONTROLLERS**

---

© 2003 CURTIS INSTRUMENTS, INC.

DESIGN OF CURTIS PMC 1200 SERIES  
CONTROLLERS PROTECTED BY U.S.  
PATENT NO. 4626750.

**CURTIS**

**CURTIS INSTRUMENTS, INC.**

200 Kisco Avenue  
Mount Kisco, NY 10509 USA  
Tel: 914-666-2971  
Fax: 914-666-2188  
[www.curtisinst.com](http://www.curtisinst.com)

1214-8 / 1215-8 / 1219-8 Manual  
p/n 16369, Rev. C: April 2003

# CONTENTS

1. OVERVIEW .....	1
2. INSTALLATION AND WIRING .....	3
Mounting the Controller .....	3
Connections: Low Current .....	4
Connections: High Current .....	5
Wiring: Standard Configuration .....	6
Wiring: Throttle .....	8
Wiring: Emergency Reverse Check .....	12
Contactors, Switches, and Other Hardware .....	13
Installation Checkout .....	14
3. PROGRAMMING AND ADJUSTMENT .....	16
4. MAINTENANCE .....	17
Cleaning .....	17
Diagnostic History .....	17
Testing the Fault Detection Circuitry .....	18
5. DIAGNOSTICS AND TROUBLESHOOTING .....	19
Programmer Diagnostics .....	19
LED Diagnostics .....	21
6. PROGRAMMER MENUS .....	22
<b>APPENDIX A</b> Glossary of Features and Functions .....	A-1
<b>APPENDIX B</b> Specifications .....	B-1

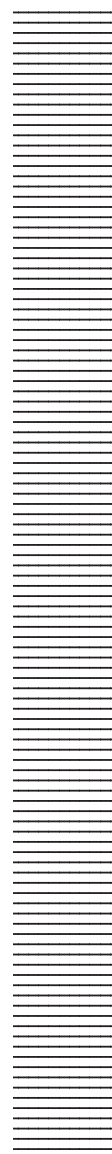

## FIGURES

FIG. 1:	Curtis 1215-8 motor controller .....	1
FIG. 2:	Mounting dimensions, Curtis 1214-/15-/19-8 controller .....	3
FIG. 3:	Standard wiring diagram .....	6
FIG. 4:	Wiring for 5k $\Omega$ -0 throttle (“Type 1”) .....	8
FIG. 5:	Wiring for 20k $\Omega$ pot used as a wigwag-style throttle (“Type 1”) .....	9
FIG. 6:	Wiring for 0-5k $\Omega$ throttle (“Type 3”) .....	9
FIG. 7:	Wiring for 0-5V throttle (“Type 2”) .....	10
FIG. 8:	Wiring for 0-10V throttle (“Type 2”) .....	11
FIG. 9:	Wiring for 3-wire pot throttle (“Type 2”) .....	11
FIG. 10:	Wiring for Curtis ET-XXX electronic throttle (“Type 2”) .....	12
FIG. A-1:	Ramp shape (throttle map) for controller with maximum speed 100% and creep speed 0 .....	A-8
FIG. A-2:	Ramp shape (throttle map) for controller with maximum speed 100% and creep speed 10% .....	A-9
FIG. A-3:	Ramp shape (throttle map) for controller with maximum speed 60% and creep speed 10% .....	A-9

## TABLES

TABLE 1:	Troubleshooting chart .....	20
TABLE 2:	LED codes .....	21

## 1

## OVERVIEW

Curtis 1214-8, 1215-8, and 1219-8 programmable motor speed controllers provide efficient, cost-effective, and simple-to-install control for a variety of large industrial vehicles. Typical applications include walkie/riders, pallet trucks, fork lifts, stackers, reach trucks, and other industrial trucks.

The 1207-based microprocessor logic section combined with a Curtis MOSFET power section gives the 1214-/15-/19-8 controller high power and advanced features in a rugged, compact package. The optional handheld programmer enables the user to set parameters, conduct tests, and obtain diagnostic information quickly and easily.

**Fig. 1** Curtis 1215-8 motor controller. The 1214-8 and 1219-8 controllers are similar, but differ in overall length.

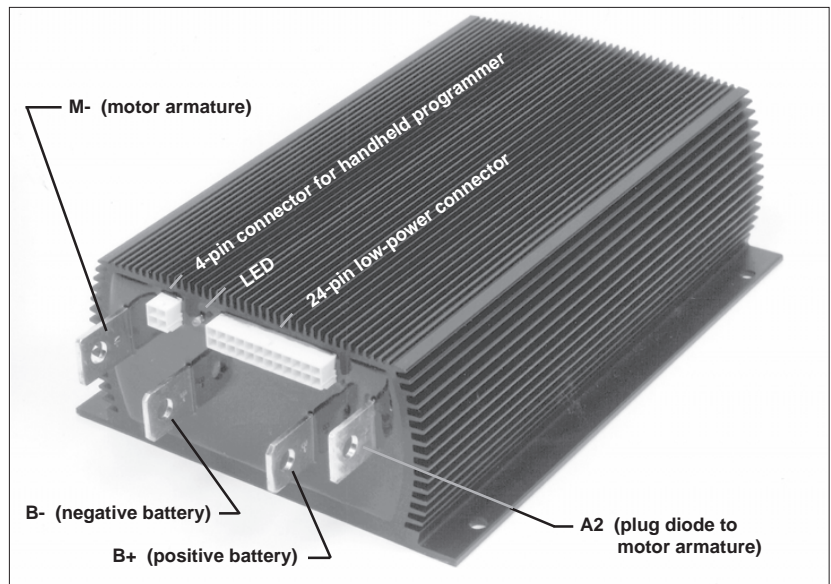

Like all Curtis motor controllers, the 1214-/15-/19-8 controller offers superior operator control of the vehicle's motor drive speed. **Features include:**

- ✓ Power MOSFET design, providing
  - infinitely variable drive and plug brake control
  - silent high-frequency operation
  - high efficiency (for reduced motor and battery losses)
- ✓ Overvoltage and undervoltage protection
- ✓ Thermal protection/compensation circuitry that provides undertemperature cutback, constant current limit over operating range,

and linear rollback in overtemperature—thus preventing sudden power loss regardless of thermal conditions

- ✓ Intelligent handheld 13XX programmer provides a full set of parameter and function settings
- ✓ Diagnostic and test information for the controller—and other system components—readily available through both an on-board LED and the optional handheld programmer
- ✓ Meets or exceeds EEC fault detect requirements, with circuitry and software to detect faults in the throttle circuit, MOSFET drive circuits, MOSFET output, contactor drivers, and contactors
- ✓ Programmable input sequencing options include several combinations of neutral start and static return to off (SRO)
- ✓ Arcless contactor switching with microprocessor-controlled contactor sequencing
- ✓ Smooth, controlled plug braking—with either variable (throttle-dependent) or fixed plug current limit
- ✓ Neutral braking option provides automatic plug braking in neutral
- ✓ MultiMode™ input selects between two different operating modes, thus allowing optimization of vehicle characteristics for different driving conditions
- ✓ Emergency reverse (belly button switch) provides full function with a single input
- ✓ Anti-rollback (ramp start) provides full power for starting on ramps
- ✓ Simple contactor and switch wiring, with coil drivers monitored for shorts and open circuits—thus ensuring fail-safe operation
- ✓ Flexible throttle circuitry accommodates a variety of throttle types: 5k $\Omega$ –0, 0–5k $\Omega$ , 0–5V, 0–10V, inductive, Hall, etc.
- ✓ Programmable “ramp shape” (static throttle map) provides flexibility in selecting throttle response feel
- ✓ Sealed package, providing environmental protection
- ✓ Power connections made by tin-plated solid copper busses, with a polarized Molex connector for control signals

Familiarity with your Curtis controller will help you install and operate it properly. We encourage you to read this manual carefully. If you have questions, please contact the Curtis office nearest you.

## 2

## INSTALLATION AND WIRING

## MOUNTING THE CONTROLLER

The controller can be oriented in any position, but **the location should be carefully chosen to keep the controller as clean and dry as possible. If a clean, dry mounting location cannot be found, a cover must be used to shield the controller from water and contaminants.**

To ensure full rated output power, the controller should be fastened to a clean, flat metal surface with four screws. The case outline and mounting hole dimensions are shown in Figure 2. Access is needed at the front of the controller to plug the programmer into its connector, and to view the LED.

Although not usually necessary, a thermal joint compound can be used to improve heat conduction from the case to the mounting surface.

**Fig. 2** Mounting dimensions, Curtis 1214-/15-/19-8 controllers.

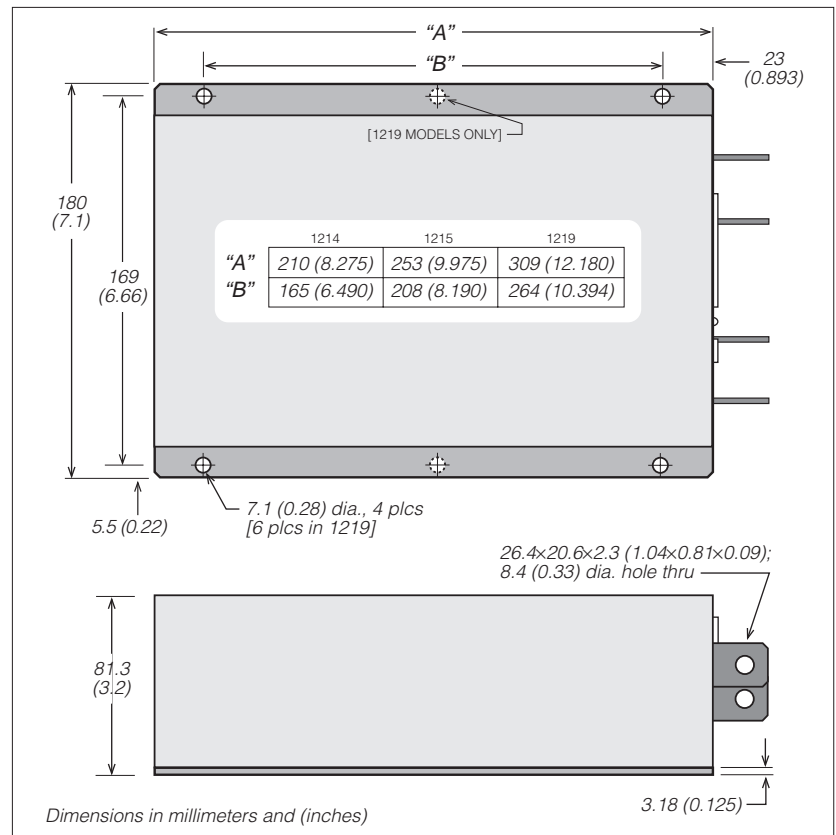

**CONNECTIONS: Low Current**

A 24-pin low current connector in the front of the controller provides the low current logic control connections (see pin list below). The mating connector is Molex Mini-Fit Jr., part number 39-01-2245. Contact Molex regarding compatible pins: 39-00-0078 for #16 AWG, 39-00-0039 for #18–24 AWG.

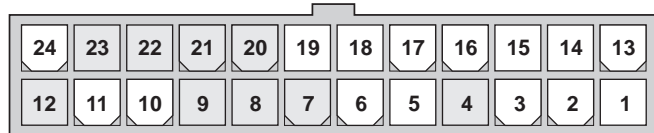

<b>Pin 1</b>	keyswitch input (KSI)
<b>Pin 2</b>	brake input
<b>Pin 3</b>	mode selection input
<b>Pin 4</b>	n/c
<b>Pin 5</b>	throttle: 0–10V
<b>Pin 6</b>	emergency reverse input
<b>Pin 7</b>	n/c
<b>Pin 8</b>	n/c
<b>Pin 9</b>	n/c
<b>Pin 10</b>	forward input
<b>Pin 11</b>	reverse input
<b>Pin 12</b>	n/c
<b>Pin 13</b>	throttle: 3-wire pot high
<b>Pin 14</b>	throttle: pot low
<b>Pin 15</b>	throttle: 0–5V (3-wire pot wiper)
<b>Pin 16</b>	throttle: 2-wire 5k $\Omega$ –0 or 0–5k $\Omega$ input
<b>Pin 17</b>	main contactor driver output
<b>Pin 18</b>	forward contactor driver output
<b>Pin 19</b>	reverse contactor driver output
<b>Pin 20</b>	n/c
<b>Pin 21</b>	n/c
<b>Pin 22</b>	n/c
<b>Pin 23</b>	n/c
<b>Pin 24</b>	emergency reverse (BB) check output [optional]

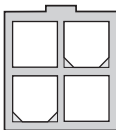

A 4-pin low power connector, also located on the front of the controller, is provided for the handheld programmer.

### CONNECTIONS: High Current

Four tin-plated solid copper bus bars are provided for the high current connections to the battery and motor:

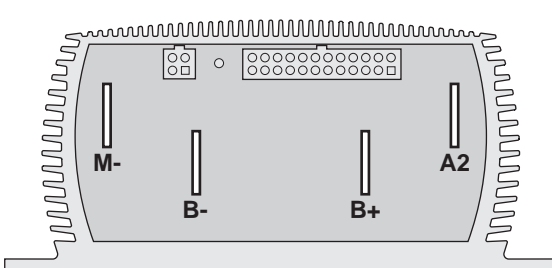

<b>M-</b>	output to motor armature
<b>B-</b>	negative connection to battery
<b>B+</b>	positive connection to battery/field
<b>A2</b>	plug diode to motor armature

Cables are fastened to the bus bars by M8 ( $\frac{5}{16}$ ") bolts. When tightening the bolts, two opposing wrenches should be used to prevent bending the bus bars and putting undue strain on the internal connections.

#### CAUTION

**Working on electric vehicles is potentially dangerous.** You should protect yourself against runaways, high current arcs, and outgassing from lead acid batteries:

**RUNAWAYS** — Some fault conditions could cause the vehicle to run out of control. Jack up the vehicle and get the drive wheels off the ground before attempting these procedures or any other work on the motor control circuitry.

**HIGH CURRENT ARCS** — Electric vehicle batteries can supply very high power, and arcs can occur if they are short circuited. Always open the battery circuit before working on the motor control circuit. Wear safety glasses, and use properly insulated tools to prevent shorts.

**LEAD ACID BATTERIES** — Charging or discharging generates hydrogen gas, which can build up in and around the batteries. Follow the battery manufacturer's safety recommendations. Wear safety glasses.



### WIRING: Standard Configuration

The configuration shown in Figure 3 is a typical arrangement for most applications. For **walkie applications**, the brake switch is typically activated by the tiller, and a belly button switch provides emergency reverse. The emergency reverse check feature (wiring shown by dotted line) is a factory option.

For **rider applications**, the brake switch is typically a seat switch or a foot switch, and there is no emergency reverse.

**Fig. 3** Standard wiring diagram, Curtis 1214-/15-/19-8 controller.

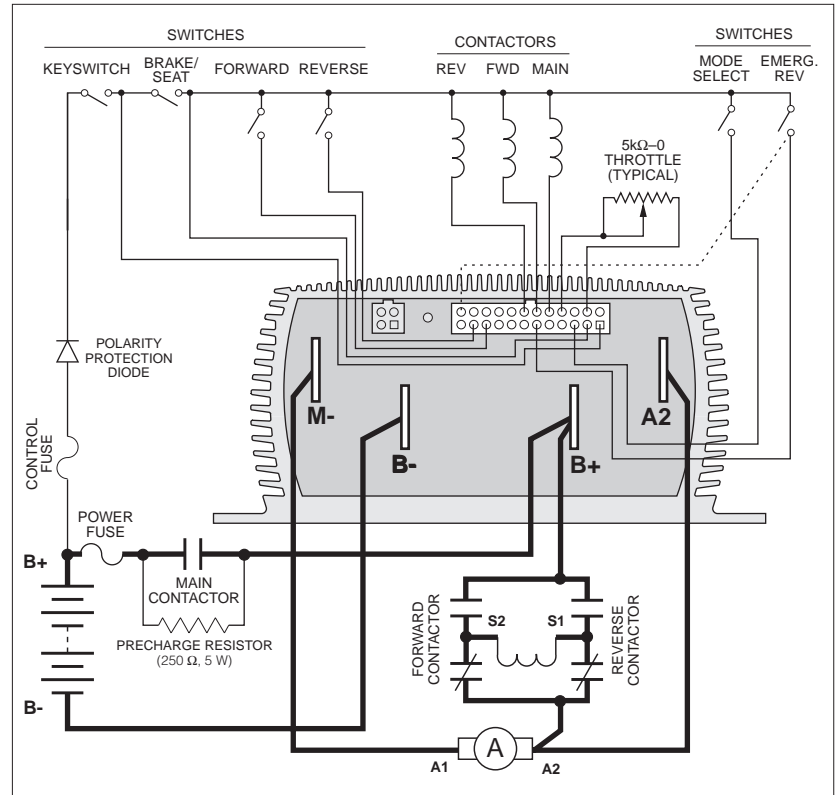

### Standard Power Wiring

In every wiring configuration, it is imperative that the field be wired between **B+** and **A2** and that the armature be wired between **M-** and the **A2** terminal. The internal plug diode used in the 1214-/15-/19-8 is connected between **M-** and **A2**. Therefore, the armature and field positions cannot be interchanged. Reversing contactors can be used to switch either the armature or the field.

### Standard Control Wiring

Wiring for the input switches and contactors is shown in Figure 3 (see detail below). The main contactor, if one is used, is normally connected directly to the controller. Optionally, the main contactor can be switched directly by the keyswitch or brake, leaving Pin 17 unconnected.

24-pin detail (see Fig. 3):

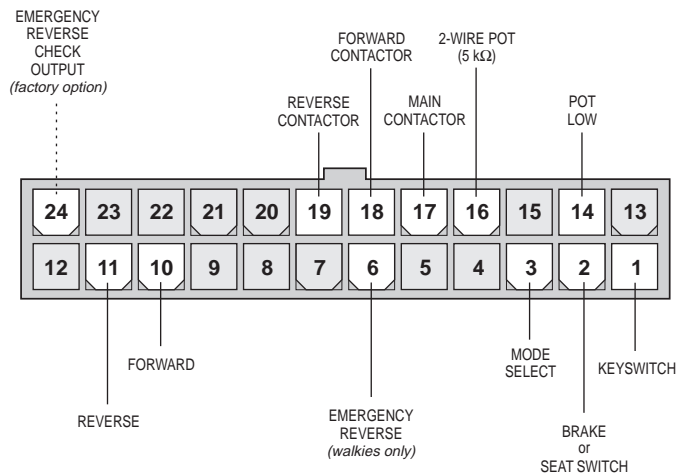

The throttle shown in Figure 3 is a 5k $\Omega$ -0 type. Various other throttles can also be accommodated, and are discussed in the throttle wiring section.

## WIRING: Throttle

Wiring for various throttles is described below. These include  $5\text{k}\Omega\text{--}0$  and  $0\text{--}5\text{k}\Omega$  throttles,  $0\text{--}5\text{V}$  and  $0\text{--}10\text{V}$  throttles, 3-wire potentiometer throttles, and electronic throttles. If the throttle you are planning to use is not covered, contact the Curtis office nearest you.

### $5\text{k}\Omega\text{--}0$ Throttle (“Type 1”)

The  $5\text{k}\Omega\text{--}0$  throttle (called a “Type 1” throttle in the programming menu of the handheld programmer) is a 2-wire resistive throttle that connects between the 2-Wire Pot pin (Pin 16) and the Pot Low pin (Pin 14), as shown in Figure 4. It doesn’t matter which wire goes on which pin. For Type 1 throttles, zero speed corresponds to  $5\text{k}\Omega$  and full speed corresponds to  $0\Omega$ .

**Fig. 4** Wiring for  $5\text{k}\Omega\text{--}0$  throttle (“Type 1”).

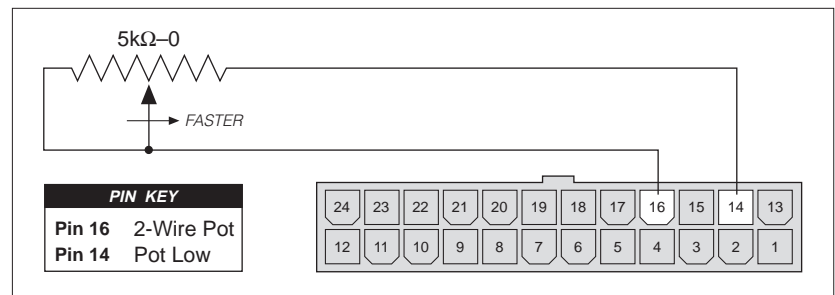

In addition to accommodating the basic  $5\text{k}\Omega\text{--}0$  throttle, the Type 1 throttle input can be used to implement a wigwag-style throttle. Using a  $20\text{k}\Omega$  potentiometer wired as shown in Figure 5, the pot wiper can be set such that the controller has  $5\text{k}\Omega$  between Pins 14 and 16 when the throttle is in the neutral position. The throttle mechanism can then be designed such that rotating it either forward or back decreases the resistance between Pins 14 and 16, which increases the controller output. The throttle mechanism must provide signals to

**Fig. 5** Wiring for  $20\text{k}\Omega$  potentiometer used as a wigwag-style throttle (“Type 1”).

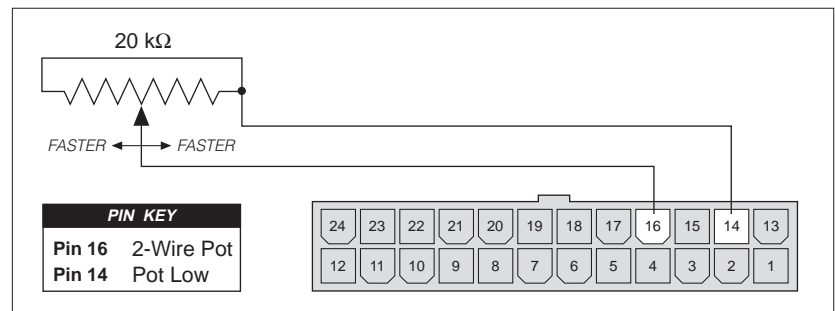

the controller's forward and reverse inputs independent of the throttle pot resistance. The controller will not sense direction from the pot resistance.

With Type 1 throttles, broken wire protection is provided by the controller sensing the current flow from the 2-Wire Pot pin through the pot and into the Pot Low pin. If the Pot Low input current falls below 0.1 mA, a throttle fault is generated and the controller is disabled. NOTE: The Pot Low pin (Pin 14) must not be tied to ground.

### 0–5k $\Omega$ Throttle (“Type 3”)

The 0–5k $\Omega$  throttle (“Type 3” in the programming menu) is a 2-wire resistive throttle that connects between the 2-Wire Pot pin (Pin 16) and Pot Low (Pin 14). It doesn't matter which wire goes on which pin. For Type 3 throttles, zero speed corresponds to 0 $\Omega$  and full speed corresponds to 5k $\Omega$ .

**Fig. 6** Wiring for 0–5k $\Omega$  throttle (“Type 3”).

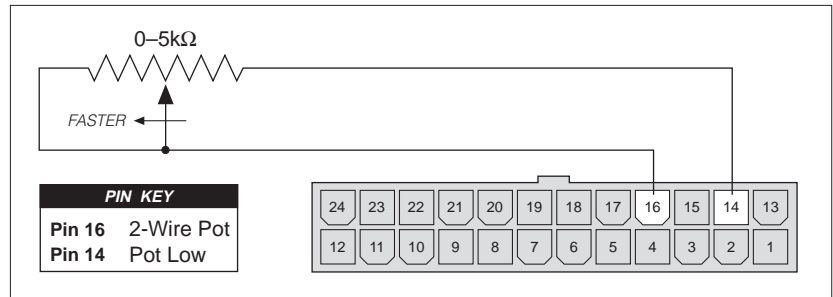

With Type 3 throttles, broken wire protection is provided by the controller sensing the current flow from the 2-Wire Pot pin through the pot and into the Pot Low pin. If the Pot Low input current falls below 0.1 mA, a throttle fault is generated and the controller is disabled. NOTE: The Pot Low pin (Pin 14) must not be tied to ground.

### 0–5V, 0–10V, 3-Wire Potentiometer, or Electronic Throttle (“Type 2”)

With these throttles (“Type 2” in the programming menu), the controller looks for a voltage signal at either the pot wiper/0–5V input (Pin 15) or the 0–10V input (Pin 5). Zero speed corresponds to 0V and full speed corresponds to either 5V or 10V. Pot Low (Pin 14) is the current return path for all Type 2 throttles. It is 200 mV above B- and must have at least 0.1 mA flowing into it to prevent pot faults.

**0–5V Throttle**

Two ways of wiring the 0–5V throttle are shown in Figure 7. Broken wire protection is provided by the controller looking for a minimum current into the Pot Low pin. If the Pot Low input current falls below 0.1 mA, a throttle fault is generated and the controller is disabled. If a throttle sensor is used, the sensor's ground return current must be less than 10 mA. If the 0–5V throttle input (Pin 15) exceeds 8 volts, the controller output will be disabled. NOTE: In Figure 7(a), the throttle's voltage input signal is in reference to Pot Low.

**Fig. 7** Wiring for 0–5V throttle (“Type 2”).

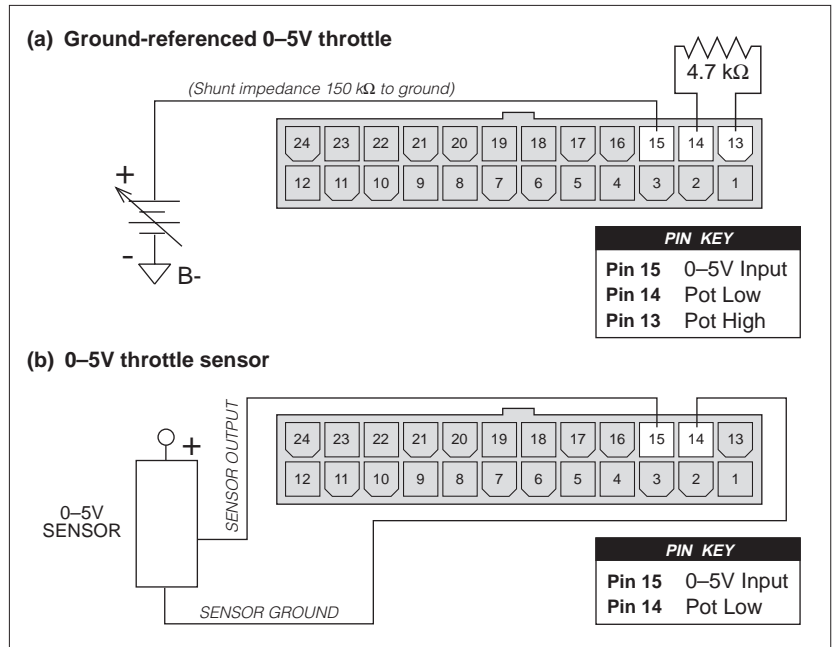
**0–10V Throttle**

Two ways of wiring the 0–10V throttle are shown in Figure 8. Broken wire protection is provided by the controller looking for a minimum current into the Pot Low pin. If the Pot Low input current falls below 0.1 mA, a throttle fault is generated and the controller is disabled. If a throttle sensor is used, the sensor's ground return current must be less than 10 mA. If the 0–10V throttle input (Pin 5) exceeds 16 volts, the controller output will be disabled. NOTE: In Figure 8(a), the throttle's voltage input signal is in reference to Pot Low.

**Fig. 8** Wiring for 0–10V throttle (“Type 2”).

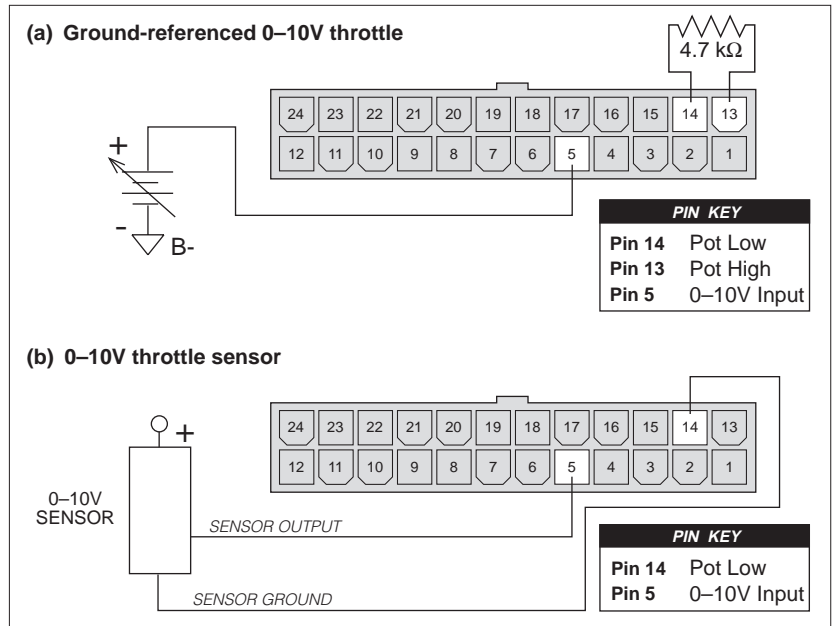

### 3-Wire Potentiometer (500Ω–10kΩ) Throttle

The 3-wire potentiometer is used in its voltage divider mode—with the voltage source and return being provided by the controller. Pot High provides a current-limited 5V source to the potentiometer, and Pot Low provides the return path. Wiring is shown in Figure 9.

**Fig. 9** Wiring for 3-wire potentiometer throttle (“Type 2”).

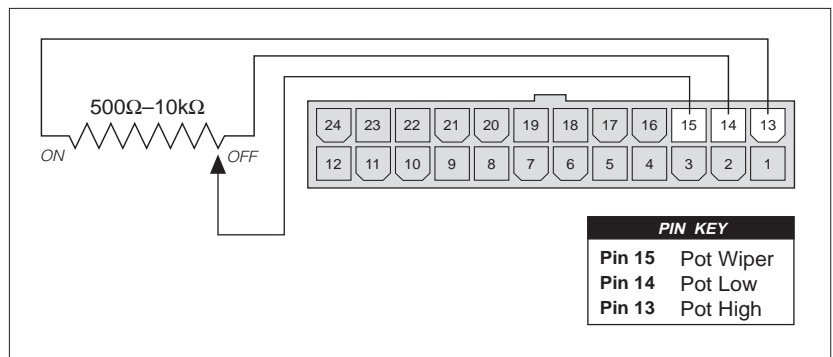

As with the 2-wire throttles, broken wire protection is provided by the controller looking for a minimum current into the Pot Low pin. If the Pot Low input current falls below 0.1 mA, a throttle fault is generated and the controller is disabled. NOTE: The Pot Low pin (Pin 14) must not be tied to ground.

*Curtis ET-XXX Electronic Throttle*

The Curtis ET-XXX provides throttle and forward/reverse inputs; wiring is shown in Figure 10.

**Fig. 10** *Wiring for Curtis ET-XXX electronic throttle (“Type 2”).*

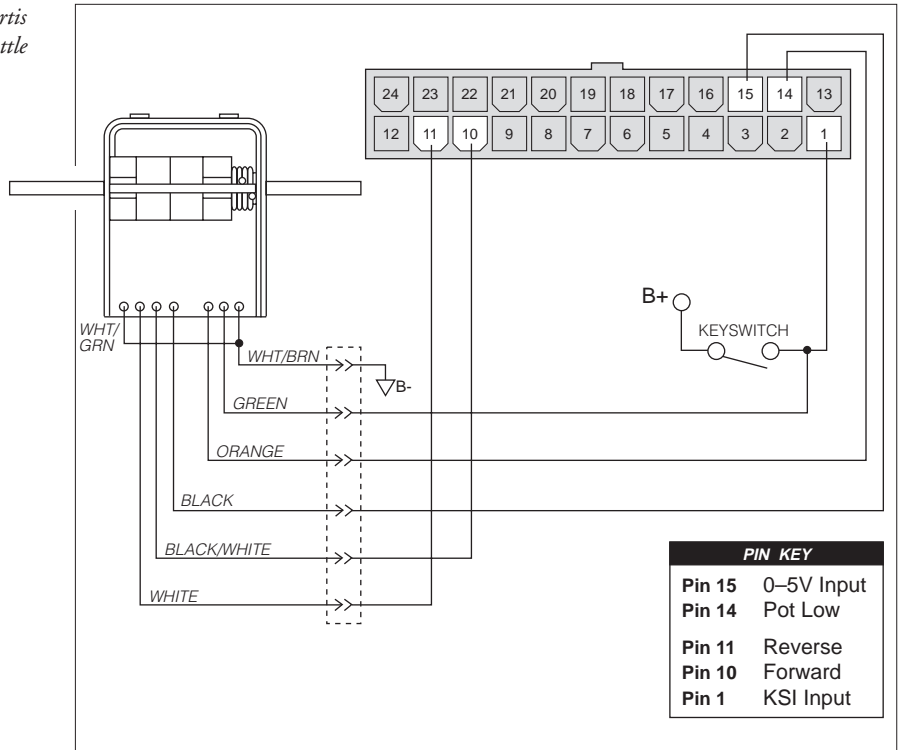

### WIRING: Emergency Reverse Check

An optional wire connected directly to the emergency reverse (belly button) switch provides for broken wire detection **when that feature is enabled at the factory**. The emergency reverse check output wire periodically pulses the emergency reverse circuit to check for continuity. If there is no continuity, the controller limits the vehicle to 15% speed and a fault code is indicated.

If the option is selected and the check wire is not connected, the vehicle speed is limited to 15%. If the option is not selected and the check wire is connected, no harm will occur—but continuity will not be checked.

The emergency reverse check output wire is connected to Pin 24, as shown by the dotted line in the basic wiring diagram (Figure 3).

## CONTACTORS, SWITCHES, and OTHER HARDWARE

### Main Contactor

A main contactor allows the controller to be disconnected from the battery. In 24V applications a main contactor is optional, but **in 36–48V applications a main contactor is required**. A heavy-duty single-pole, single-throw (SPST) contactor with silver-alloy contacts is recommended.

After initial closing of the contacts, inrush currents flow as the controller's internal filter capacitors are charged. A 250 $\Omega$ , 5W resistor can be used across the contactor to precharge the capacitors and reduce the inrush current through the contacts.

A built-in coil suppression diode is connected between the main contactor coil output and the brake/seat switch input.

### Forward/Reverse Contactors

For forward/reverse, a paired single-pole, double-throw (2 $\times$ SPDT) contactor is recommended. With 4-terminal split field motors, two single-pole, single-throw (SPST) contactors are typically used. The coil voltage should match the vehicle voltage. The maximum allowed coil current is 1 ampere.

A built-in coil suppression diode is connected between each forward/reverse contactor coil output and the brake/seat switch input.

### Forward/Reverse, Emergency Reverse, and Mode Selection Switches

These switches can be any type of single-pole, single-throw (SPST) switch capable of switching the battery voltage at 10 mA.

### Keyswitch

The vehicle should have a master on/off switch to turn the system off when not in use. The keyswitch provides logic power for the controller, and coil current for the contactors. The keyswitch must be capable of carrying these currents.

### Circuitry Protection Devices

For reverse polarity protection, a diode should be added to the control circuit. It must be sized appropriately for the maximum contactor coil currents. To protect the control wiring from accidental shorts, a low current fuse (appropriate for the maximum current draw) should be connected in series with the battery feed. These devices are both shown in the wiring diagrams.



## INSTALLATION CHECKOUT

Before operating the vehicle, carefully complete the following checkout procedure. If you find a problem during the checkout, refer to the diagnostics and troubleshooting section (Section 5) for further information.

The installation checkout can be conducted with or without the handheld programmer. The checkout procedure is easier with a programmer. Otherwise, observe the LED for diagnostic codes. (The codes are listed in Section 5.)



**Put the vehicle up on blocks to get the drive wheels off the ground before beginning these tests.**

**Do not stand, or allow anyone else to stand, directly in front of or behind the vehicle during the checkout.**

**Make sure the keyswitch is off and the brake is applied (brake switch open), the throttle is in neutral, and the forward/reverse switches are open.**

**Wear safety glasses and use well-insulated tools.**

1. If a programmer is available, connect it to the programmer connector.
2. Turn the keyswitch on. The programmer should “power up” with an initial display, and the controller’s Status LED should begin steadily blinking a single flash. If neither happens, check for continuity in the keyswitch circuit and controller ground.
3. If you are using a programmer, put it into the diagnostic mode by pressing the **DIAGNOSTICS** key. The display should indicate “No Faults Found.”

Close the brake/seat switch. To do this on a walkie, pull the tiller down to the operating position. The LED should continue blinking a single flash and the programmer should continue to indicate no faults. If there is a problem, the LED will flash a diagnostic code and the programmer will display a diagnostic message. If you are conducting the checkout without a programmer, look up the LED diagnostic code in Section 5 (Diagnostics and Troubleshooting).

When the problem has been corrected, it may be necessary to cycle the brake/seat switch in order to clear the fault code.

4. With the brake/seat switch closed, select a direction and operate the throttle. The motor should begin to turn in the selected direction. If it does not, verify the wiring to the forward/reverse switches, forward/reverse contactors, and motor. The motor should run proportionally faster with increasing throttle. If not, refer to Section 5.
5. If you are using a programmer, put it into the test mode by pressing the **TEST** key. Scroll down to observe the status of the forward, reverse, brake, emergency reverse, and mode switches. Cycle each switch in turn, observing the programmer. Each input should show the correct state on the programmer.
6. Specific material handling directives, such as prEN1175, require testing of the controller's fault detection circuitry. This can be done as follows:
  - a) Disconnect the battery and make sure the keyswitch is off.
  - b) Using an inline fuse holder fitted with a 10-amp fuse and alligator clips, connect the controller's M- and B- terminals.
  - c) Turn the keyswitch on, release the brake, and apply the throttle. The motor should not operate, and the direction contactors should not pull in.
  - d) Leave the keyswitch on and remove the inline fuse wire. The vehicle status should continue to remain off.
  - e) Cycle the keyswitch off and on, release the brake, and apply the throttle. The vehicle should now operate normally.
7. Take the vehicle off the blocks and drive it in a clear area. It should have smooth acceleration and good top speed.
8. Test the plug braking of the vehicle. Verify that the plug braking option is as desired (variable or fixed).
9. Verify that all options, such as high pedal disable (HPD), static return to off (SRO), and anti-tiedown, are as desired.
10. On walkies, check to see whether the emergency reverse (belly button) feature is working correctly. If you have the optional emergency reverse check wiring, verify that the circuit is operational by momentarily disconnecting one of the emergency reverse wires. The vehicle should be limited to 15% speed and a fault indicated.
11. If you used a programmer, disconnect it when you have completed the checkout procedure.

# 3

## PROGRAMMING AND ADJUSTMENT

To change a parameter using the programmer, press the **PROGRAM** key, and scroll down the Program Menu until the desired parameter is the top line of the display. Press the appropriate **CHANGE VALUE** key (“up” or “down”) until the desired number is reached. The parameter is now set at the desired value. All programming occurs in real time. In other words, the parameters can be changed while the vehicle is in operation.

The upper and lower limits of parameters are set at the factory. When the programmer is used to adjust a parameter and a limit is reached, the display stops changing. To see why the display has stopped changing, press the **MORE INFO** key. If the limit is related to another parameter, that information will be displayed; changing the value of the related parameter may allow the original parameter to be adjusted further. Otherwise, the display says “Max Limit” or “Min Limit.”

In addition to adjusting parameters, the programmer can be used to change various options—such as throttle type, HPD, SRO, etc. Typically, the brake/seat switch must be cycled before the new options take effect.

### “CLONING”

One of the most powerful features of the programmer is its ability to “clone” controllers. The programmer can read all the parameters and options from one controller and write them to other controllers. Cloning only works between controllers with the same model number and software version.

For example, the programmer can read all the information from a 1215-8105 controller and write it to other 1215-8105 controllers. However, it cannot write that same information to 1215-8106 controllers. If this is attempted, an error message will be displayed.

### PEACE-OF-MIND PROGRAMMING

Each time the programmer is connected to the controller, it acquires all the controller’s parameters and stores them in its temporary memory. You can revert back to these original settings at any time during a programming session via the Special Program Menu. Select “Reset All Settings” by scrolling it to the top of the display window, press the **MORE INFO** key, and follow the instructions displayed. Any inadvertent changing of parameters can be “undone” using this procedure—even if you can’t remember what the previous settings were—**as long as the programmer has not been unplugged and power has not been removed from the controller.**

# 4

## MAINTENANCE

There are no user-serviceable parts inside Curtis controllers. **No attempt should be made to open the controller.** Opening the controller may damage it and will void the warranty.

However, it is recommended that the controller exterior be cleaned periodically, and—if a handheld programmer is available—this periodic cleaning provides a good opportunity to check the controller’s diagnostic history file.



The 1214-/15-/19-8 controller is inherently a high power device. **When working around any battery powered vehicle, proper safety precautions should be taken.** These include, but are not limited to: proper training, wearing eye protection, avoiding loose clothing and jewelry, and using insulated wrenches.

### CLEANING

Although the 1214-/15-/19-8 controller requires virtually no maintenance when properly installed, the following minor maintenance is recommended in certain applications.

1. Remove power by disconnecting the battery.
2. Discharge the capacitors in the controller by connecting a load (such as a contactor coil or a horn) across the controller’s B+ and B- terminals.
3. Remove any dirt or corrosion from the bus bar area. The controller should be wiped clean with a moist rag. Allow it to dry before reconnecting the battery.
4. Make sure the connections to the bus bars are tight. Use two wrenches for this task in order to avoid stressing the bus bars; the wrenches should be well insulated.

### DIAGNOSTIC HISTORY

The handheld programmer can be used to access the controller’s diagnostic history file. Connect the programmer, press the **MORE INFO** key, and then—while continuing to hold the **MORE INFO** key—press the **DIAGNOSTICS** key. The programmer will read out all the faults that the controller has experienced since the last

time the diagnostic history file was cleared. The faults may be intermittent faults, faults caused by loose wires, or faults caused by operator errors. Faults such as contactor faults may be the result of loose wires; contactor wiring should be carefully checked out. Faults such as HPD or overtemperature may be caused by operator habits or by overloading.

After a problem has been diagnosed and corrected, clearing the diagnostic history file is advisable. This allows the controller to accumulate a new file of faults. By checking the new diagnostic history file at a later date, you can readily determine whether the problem was indeed completely fixed.

To clear the diagnostic history file, go to the Special Program Menu (by pressing and holding the **[MORE INFO]** key, and then pressing the **[PROGRAM]** key), scroll through the menu until “Clear Diagnostic History” is the top line in the display, and then press **[MORE INFO]** again. The programmer will prompt you to acknowledge or cancel. See Section 6 of this manual for more detail on programmer operation.

## **TESTING THE FAULT DETECTION CIRCUITRY**

Specific material handling directives, such as prEN1175, require periodic testing of the controller’s fault detection circuitry. It is recommended that each time the vehicle is serviced, the M- fault detection circuitry be checked as follows:

1. Put the vehicle up on blocks to get the drive wheel(s) off the ground, disconnect the battery, and make sure the keyswitch is off.
2. Using an inline fuse holder fitted with a 10-amp fuse and alligator clips, connect the controller’s M- and B- terminals.
3. Turn the keyswitch on, release the brake, and apply the throttle. The motor should not operate, and the direction contactors should not pull in.
4. Leave the keyswitch on and remove the inline fuse wire. The vehicle status should continue to remain off.
5. Cycle the keyswitch off and on, release the brake, and apply the throttle. The vehicle should now operate normally.

# 5

## DIAGNOSTICS AND TROUBLESHOOTING

### PROGRAMMER DIAGNOSTICS

With a programmer, the diagnostics and troubleshooting process is more direct than with the LED alone. The programmer presents complete diagnostic information in plain language—no codes to decipher. Faults are displayed in the Diagnostic Menu, and the status of the controller inputs/outputs is displayed in the Test Menu.

The following 4-step process is generally used for diagnosing and troubleshooting an inoperative vehicle: (1) visually inspect the vehicle for obvious problems; (2) diagnose the problem, using the programmer; (3) test the circuitry with the programmer; and (4) correct the problem. Repeat the last three steps as necessary until the vehicle is operational.

**Example:** A vehicle that does not operate in “forward” is brought in for repair.

STEP 1: Examine the vehicle and its wiring for any obvious problems, such as broken wires or loose connections.

STEP 2: Connect the programmer, put it in diagnostic mode, and read the displayed fault information. In this example, the display shows “No Faults Present,” indicating that the controller has not detected anything out of the norm.

STEP 3: Put the programmer in test mode, and observe the status of the inputs and outputs in the forward direction. In this example, the display shows that the forward switch did not close when “forward” was selected, which means the problem is either in the forward switch or the switch wiring.

STEP 4: Check or replace the forward switch and wiring and repeat the test. If the programmer shows the forward switch closing and the vehicle now drives normally, the problem has been corrected.

Refer to the troubleshooting chart (Table 1) for suggestions covering a wide range of possible faults.

**Table 1 TROUBLESHOOTING CHART**

LED CODE	PROGRAMMER LCD DISPLAY	EXPLANATION	POSSIBLE CAUSE
1,2	HW FAILSAFE	hardware fail-safe error	1. Controller defective.
1,3	M- FAULT	M- output shorted	1. M- output shorted to ground. 2. Internal motor short to ground.
1,4	SRO	SRO fault	1. Improper sequence of KSI, brake, and direction inputs. 2. Wrong SRO type selected. 3. Brake or direction switch circuit open. 4. Sequencing delay too short.
2,1	THROTTLE FAULT 1	5k $\Omega$ -0 or wiper fault	1. Throttle input wire open. 2. Throttle input wire shorted to ground or B+. 3. Throttle pot defective. 4. Wrong throttle type selected.
2,2	BB WIRING CHECK	emerg. reverse wiring fault	1. BB wire open. 2. BB check wire open.
2,3	HPD	HPD sequencing fault	1. Improper seq. of KSI, brake, throttle inputs. 2. Wrong HPD type selected. 3. Misadjusted throttle pot. 4. Sequencing delay too short.
2,4	THROTTLE FAULT 2	Pot Low broken or shorted	1. Pot Low wire open. 2. Pot Low wire shorted. 3. Wrong throttle type selected.
3,1	CONT DRVR OC	driver output overcurrent	1. Direction contactor coil shorted.
3,2	DIR CONT WELDED	welded direction contactor	1. Direction contactor stuck closed.
3,4	MISSING CONTACTOR	missing contactor	1. Direction contactor coil open. 2. Direction contactor missing. 3. Wire to direction contactor open.
4,1	LOW BATTERY VOLTAGE	low battery voltage	1. Battery voltage <16 volts (24–36V models) or <21 volts (36–48V models). 2. Corroded or loose battery terminal. 3. Loose controller terminal.
4,2	OVERVOLTAGE	overvoltage	1. Battery voltage >46 volts (24–36V models) or >60 volts (36–48V models). 2. Vehicle operating with charger attached.
4,3	THERMAL CUTBACK	over-/under-temp. cutback	1. Temperature >85°C or <-25°C. 2. Excessive load on vehicle. 3. Improper mounting of controller. 4. Operation in extreme environments.

## LED DIAGNOSTICS

During normal operation, with no faults present, the LED on the controller's front face flashes a single flash at approximately 1 flash/second. If the controller detects a fault, a 2-digit code (see Table 2) is flashed continuously until the fault is corrected. For example, code "3,2"—welded direction contactor—appears as:

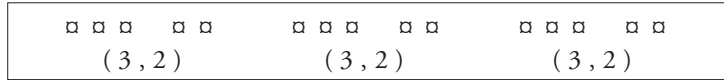

<b>Table 2 LED CODES</b>		
LED CODE		EXPLANATION
<i>LED off</i>	████████	no power or defective controller
<i>solid on</i>	□□□□	defective controller
<i>single flash</i>	□	controller operational; no faults
1,2	□ □ □	hardware fail-safe error
1,3	□ □ □ □	M- fault or motor output short
1,4	□ □ □ □ □	sequencing fault (SRO)
2,1	□ □ □	5kΩ-0 or throttle wiper input fault
2,2	□ □ □ □	emerg. rev. circuit check fault (BB wiring)
2,3	□ □ □ □ □	high-pedal-disable fault (HPD)
2,4	□ □ □ □ □ □	throttle pot low open or shorted to B+ or B-
3,1	□ □ □ □ □	contactor driver overcurrent
3,2	□ □ □ □ □ □	welded direction contactor
3,3	□ □ □ □ □ □ □	[reserved for future use]
3,4	□ □ □ □ □ □ □ □	missing contactor
4,1	□ □ □ □ □ □ □	low battery voltage
4,2	□ □ □ □ □ □ □ □	overvoltage
4,3	□ □ □ □ □ □ □ □ □	thermal cutback
4,4	□ □ □ □ □ □ □ □ □ □	[reserved for future use]

NOTE: Only one fault is indicated at a time, and faults are not queued up. Operational faults—such as a fault in SRO sequencing—are cleared by cycling the brake/seat switch or keyswitch. (See “Fault recovery” in Appendix A for more information.)



# 6

## PROGRAMMER MENUS

Items are listed for each menu in the order they appear in the actual menus displayed by the handheld programmer.

### **Program Menu** *(not all items available on all controllers)*

EMR REV C / L	Emergency reverse current limit
THROTTLE TYPE	Throttle type*
RAMP SHAPE	Throttle map
CREEP SPEED	Creep speed, as percent PWM duty cycle
EMR REV SPEED	Emerg. reverse speed, as % PWM duty cycle
SEQUENCING DLY	Sequencing delay, in seconds
VARIABLE PLUG	Throttle-variable plug braking: on or off
HIGH PEDAL DIS	High pedal disable (HPD): type†
SRO	Static return to off (SRO): type‡
ANTI - TIEDOWN	Anti-tiedown: on or off
QUICK START	Quick-start throttle factor
M1 MAIN C / L	Mode 1 main current limit
M1 PLUG C / L	Mode 1 plug current limit
M1 RAMP C / L	Mode 1 ramp start current limit
M1 ACCEL RATE	Mode 1 acceleration rate, in seconds
M1 MAX SPEED	Mode 1 maximum speed, as % PWM output
M2 MAIN C / L	Mode 2 main current limit
M2 PLUG C / L	Mode 2 plug current limit
M2 RAMP C / L	Mode 2 ramp start current limit
M2 ACCEL RATE	Mode 2 acceleration rate, in seconds
M2 MAX SPEED	Mode 2 maximum speed, as % PWM output
NEUT BRAKE C / L	Neutral brake current limit
NEUTRAL BRAKE	Neutral brake: on or off

*(Notes are on the next page.)*

## Program Menu Notes

(For more detail on these options, see Appendix A: Glossary of Features and Functions.)

### \* Throttle types

*Type 1:* 5k $\Omega$ -0

*Type 2:* 0-5V, 0-10V, 3-wire pot, and electronic throttles

*Type 3:* 0-5k $\Omega$

### † HPD types

*Type 0:* no HPD

*Type 1:* HPD fault unless KSI input and brake input before throttle input

*Type 2:* HPD fault unless KSI input before throttle input

### ‡ SRO types

*Type 0:* no SRO

*Type 1:* SRO fault unless brake input before direction input

*Type 2:* SRO fault unless KSI before brake input before direction input

*Type 3:* SRO fault unless KSI before brake input before forward input

## Test Menu (not all items available on all controllers)

FORWARD SWITCH	Forward switch: on/off
REVERSE SWITCH	Reverse switch: on/off
BRAKE SWITCH	Brake switch: on/off
THROTTLE %	Throttle reading, in percent of full
SPEED SWITCH	Speed switch: on/off
EMR REV SWITCH	Emergency reverse switch: on/off
FWD CONTACTOR	Forward contactor: on/off
REV CONTACTOR	Reverse contactor: on/off
BATT VOLTAGE	Battery voltage
HEAT SINK °C	Heatsink temperature
MAX TEMP °C	Maximum temperature seen *
MIN TEMP °C	Minimum temperature seen *

\* Maximum/minimum temperatures recorded while controller active. After controller power is cycled, the initially recorded temperatures will be accurate only to within 10°C.

### ***Special Program Menu***

RESET ALL SETTINGS	Revert to original settings
CONT SETTINGS → PROG	Save controller settings in programmer
PROG SETTINGS → CONT	Load programmer settings in controller
CLEAR DIAG HISTORY	Clear diagnostic history memory
CONTRAST ADJUSTMENT	Adjust display contrast
LANGUAGE SELECTION	Select displayed language
PROGRAMMER INFO	Display programmer information
CONTROLLER INFO	Display controller information

### ***Diagnostics and Special Diagnostics “Menu”***

This is not a menu as such, but simply a list of the possible messages you may see displayed when the programmer is operating in either of the Diagnostics modes. The messages are listed in alphabetical order for easy reference.

BB WIRING CHECK	BB wiring check failed
CONT DRVR OC	Contactor driver overcurrent
DIR CONT WELDED	Direction contactor welded
HPD	High-pedal-disable activated
HW FAILSAFE	Hardware failsafe activated
LOW BATTERY VOLTAGE	Battery voltage too low*
M- FAULT	M- output fault
MISSING CONTACTOR	Missing contactor
NO KNOWN FAULTS	No known faults
OVERVOLTAGE	Battery voltage too high†
SRO	Static-return-to-off activated
THERMAL CUTBACK	Thermal cutback due to temperature
THROTTLE FAULT 1	Throttle input fault
THROTTLE FAULT 2	Throttle low input fault

\* <16 volts (24–36V models); <21 volts (36–48V models)

† >46 volts (24–36V models); >60 volts (36–48V models)

## APPENDIX A

### GLOSSARY OF FEATURES AND FUNCTIONS

#### **Acceleration rate**

The acceleration rate is the time required for the controller to increase from 0% to 100% duty factor. The shape of the acceleration curve is controlled by the dynamic throttle response, which is linear.

If you have a MultiMode™ controller, the acceleration rates in Mode 1 and in Mode 2 are independently adjustable via the handheld programmer. If you have a 1207 controller with the MultiMode™ feature disabled (i.e., a single-mode controller), you can adjust the acceleration rate mechanically via the appropriate trimpot located on top of the controller.

#### **Anti-rollback** (*see Ramp start*)

#### **Anti-tiedown**

Before enabling Mode 1 operation, the anti-tiedown function checks that the mode selection switch has been released after the last cycling of the brake switch. This feature discourages operators from taping or otherwise “tying down” the mode switch. If Mode 1 is already selected before the brake is released, the controller remains in Mode 2 until the mode switch is released and pressed again. For information on how Mode 1 and Mode 2 are selected, see *MultiMode™*.

#### **Arcless contactor switching**

The controller output duty factor is quickly reduced to zero any time a direction is de-selected, so that the controller current will be reduced to zero before the direction contactor drops out.

#### **BB** (= *Belly Button; see Emergency reverse*)

#### **Brake/seat switch**

This is a controller-enable input connected to the brake on a walkie or to the seat of a rider. The brake/seat switch must be closed for the controller to operate. This safety interlock is used on most material handling vehicles.

Cycling the brake/seat switch or KSI clears most faults and enables operation.

## Contactor drivers and circuits

The controller can accommodate three external contactors: forward, reverse, and main. Some vehicles may have no main contactor, or the main contactor may be wired directly to the KSI or brake signal, bypassing the controller.

Various protections provided for the contactor drivers ensure that the contactors operate correctly; see *“Fault detection”* below.

## Creep speed at first throttle

Creep speed is activated when a direction is first selected. The output maintains creep speed until the throttle is rotated out of the throttle deadband (typically 10% of throttle). Creep speed is adjustable from 0 to 25% of the controller duty factor. This adjustment can be made electronically via the handheld programmer.

## Current limiting

Curtis controllers limit the motor current to a preset maximum. This feature protects the controller from damage that might result if the current were limited only by motor demand. PWM output to the power section is reduced smoothly until the motor current falls below the set limit level.

In addition to protecting the controller, the current limit feature also protects the rest of the system. By eliminating high current surges during vehicle acceleration, stress on the motor and batteries is reduced and their efficiency enhanced. Similarly, there is less wear and tear on the vehicle drivetrain.

The main current limit, plug current limit, ramp start current limit, emergency reverse current limit, and optional neutral brake plug current limit are all adjustable via the handheld programmer.

Three of these current limits—main, plug, and ramp start—are independently adjustable in Mode 1 and Mode 2.

## Current multiplication

During acceleration and during reduced speed operation, the Curtis controller allows more current to flow into the motor than flows out of the battery. The controller acts like a dc transformer, taking in low current and high voltage (the full battery voltage) and putting out high current and low voltage. The battery needs to supply only a fraction of the current that would be required if a resistive

controller were used. The current multiplication feature gives vehicles using Curtis controllers dramatically greater driving range per battery charge.

### **Deceleration rate**

The deceleration rate is the time required for the controller to decrease from 100% duty factor to zero. The deceleration rate is fixed, and cannot be adjusted. The shape of the deceleration curve is controlled by the dynamic throttle response, which is linear.

### **Disable recovery** (*see Fault recovery*)

### **Emergency reverse**

Emergency reverse is activated when the brake switch is closed (brake released), KSI is activated, and the emergency reverse switch (the BB, or “belly button” switch) is pressed. After the BB switch is released, normal controller operation is not resumed until neutral (no direction) is selected or until the brake is cycled (brake, then brake release). However, repeatedly pressing the BB switch will reactivate the emergency reverse function each time.

Because emergency reverse immediately powers the reverse contactor, some arcing may occur.

### **Fault detection**

An internal microcontroller automatically maintains surveillance over the functioning of the controller. When a fault is detected, the appropriate fault code is signalled via the LED, which is externally visible on the front face of the controller. The diagnostic codes flashed by the LED are listed in Section 5, Troubleshooting.

If the fault is critical, the controller is disabled. More typically, the fault is a remediable condition and temporary—for example, an undervoltage fault is cleared when the condition is removed.

The automatic fault detection system includes:

- emergency reverse circuit check
- F/R contactor coil open / shorted driver
- F/R contactor driver overcurrent / contactor coil short
- F/R contactor welded

- M- fault
- memory checks upon start-up
- overvoltage cutoff
- power supply out of range (internal)
- throttle fault
- undervoltage cutback
- watchdog (external)
- watchdog (internal).

### Fault recording

Fault events are recorded in the controller's memory. Multiple occurrences of the same fault are recorded as one occurrence.

The fault event list can be loaded into the programmer for readout. The Special Diagnostics mode provides access to the controller's diagnostic history file—the entire fault event list created since the diagnostic history file was last cleared. The Diagnostics mode, on the other hand, provides information about only the currently active faults.

### Fault recovery (including recovery from disable)

Almost all faults require a cycling of the KSI or brake/seat switch input to reset the controller and enable operation.

The only exceptions are these:

FAULT	RECOVERY
anti-tiedown	release and re-select Mode 1
contactor overcurrent	when condition clears
emergency reverse	re-apply BB <u>or</u> cycle brake
HPD	lower throttle to below HPD threshold
overvoltage	when battery voltage drops below overvoltage
SRO	when proper sequence is followed
thermal cutback	when temperature changes
throttle fault	clears when condition is gone
undervoltage	when battery voltage rises above undervoltage
<i>(all other faults)</i>	<i>(cycle KSI or brake/seat switch)</i>

## High-pedal-disable (HPD)

The HPD feature prevents controller output if the controller is turned on while the throttle is not in neutral. The controller can be programmed to have HPD based either on brake/seat switch input or on KSI.

### *Brake-type HPD*

To start a vehicle with brake-type HPD, the controller must receive a brake/seat switch input before receiving a throttle input. Controller operation will be disabled immediately if pedal demand (throttle input) is greater than 25% duty factor at the time the brake/seat switch is closed. Normal controller operation is regained by reducing the throttle demand to less than 25%.

Sequencing delay, which can be set with the handheld programmer, provides a variable delay before disabling the controller. If the brake/seat switch is opened while the throttle is above the HPD threshold (25%), HPD is not activated if the brake/seat switch is then closed before the delay time elapses.

### *KSI-type HPD*

The HPD feature can be activated by KSI input instead of brake/seat switch input, if preferred. To start a vehicle with this type of HPD, the controller must receive a KSI input before receiving a throttle input.

## KSI

KSI (Key Switch Input) provides power to the controller's logic board, and initializes and starts diagnostics. In combination with the brake input, KSI enables all logic functions.

Some vehicles may have no keyswitch (KSI simply tied to B+) or may have the key permanently turned on.

## LED

An LED on the controller's front face flashes a code if a fault is detected by the controller. The fault codes are listed in Table 2 (page 21). The fault code will continue to flash until the fault condition has been cleared during active fault detection. This will typically happen after cycling KSI for power-up fault conditions, and cycling the brake/seat switch for faults detected during operation.



## MOSFET

A MOSFET (**m**etal **o**xide **s**emiconductor **f**ield **e**ffect **t**ransistor) is a type of transistor characterized by its fast switching speeds and very low losses.

## MultiMode™

The MultiMode™ feature of these controllers allows the vehicle to be operated with two distinct sets of characteristics. The two modes can be programmed to be suitable for operation under different conditions, such as slow precise maneuvering in Mode 2 and faster, long distance travel in Mode 1. The following parameters can be set independently in the two modes:

- main current limit
- plug current limit
- ramp start current limit
- acceleration rate
- maximum speed

The operating mode is selected by means of the mode selection switch. As a factory standard, Mode 1 is selected when the mode selection switch (Pin 3) is pulled high. Otherwise, the controller operates by default in Mode 2. When the controller transitions between modes, it automatically changes the main current limit, the plug current limit, the ramp start current limit, the acceleration rate, and the maximum speed to their individual mode-specific settings.

If the anti-tiedown feature is active, Mode 1 must be re-selected each time the brake is released.

## Neutral brake

The optional neutral brake feature provides automatic plug braking in neutral. If this option is not selected, the vehicle is free to coast in neutral. The neutral brake plug current limit is programmable.

## Overtemperature

At overtemperature (from 85°C to 95°C), the drive current limit is linearly decreased from full set current down to zero. (Plug current, however, is not reduced—in order to provide full vehicle braking under all thermal conditions.) The operating PWM frequency is shifted to 1.5 kHz when the controller is operating in the overtemperature range.

## Overvoltage protection

Overvoltage resets the microprocessor, inhibits the PWM, and opens the contactors, thereby shutting down the controller. Overvoltage can result during battery charging or from an improperly wired controller. Controller operation resumes when the voltage is brought within the acceptable range. The cutoff voltage and re-enable voltage are percentages of the battery voltage, and are set at the factory.

## Plug braking

Plug braking takes place when a series motor is driven electrically in a direction opposite from the direction it is turning. The 1214-/15-/19-8 controls the field current to obtain smooth and controlled plug braking torque. During plug braking, the maximum current limit is automatically changed to the plug current limit, and the PWM frequency is changed to 1.5 kHz. NOTE: Plug current limit controls the field current; the armature current in plug mode will be higher than the field current.

There are two types of plug braking control—fixed and variable. The fixed plug current limit is set to a fixed level. The variable plug current limit varies the current limit to correspond to the throttle position.

The Mode 1 and Mode 2 plug current limits are independently adjustable via the handheld programmer.

## PWM

Pulse width modulation (PWM), also called “chopping,” is a technique that switches battery voltage to the motor on and off very quickly, thereby controlling the speed of the motor. Curtis 1200 series controllers use high frequency PWM—15 kHz—which permits silent, efficient operation.

## Quick-start

Upon receiving a quick throttle demand from neutral, the controller will exceed normal acceleration momentarily in order to overcome inertia. The “quick-start” algorithm is applied each time the vehicle passes through neutral and is not in plug mode. If the vehicle is in plug, the quick-start function is disabled, allowing normal plug braking to occur. The quick-start throttle factor is adjustable via the handheld programmer.

## Ramp shape (throttle map)

“Ramp shape” is a programmable parameter that determines the static throttle map of the 1214-/15-/19-8 controller. Eleven preprogrammed ramp shapes are available, in 5% steps between 20% and 70% (20, 25, 30, 35, 40, 45, 50, 55, 60, 65, and 70%). The ramp shape number refers to the PWM output at half throttle, as a percentage of its full range. For example, if maximum speed is set at 100% and creep speed is set at 0, a ramp shape of 50% will give 50% output at half throttle. The 50% ramp shape corresponds to a linear response. The six “even number” ramp shapes for maximum and creep speeds set at 100% and 0 are shown in Figure A-1.

**Fig. A-1** Ramp shape (throttle map) for controller with maximum speed set at 100% and creep speed set at 0.

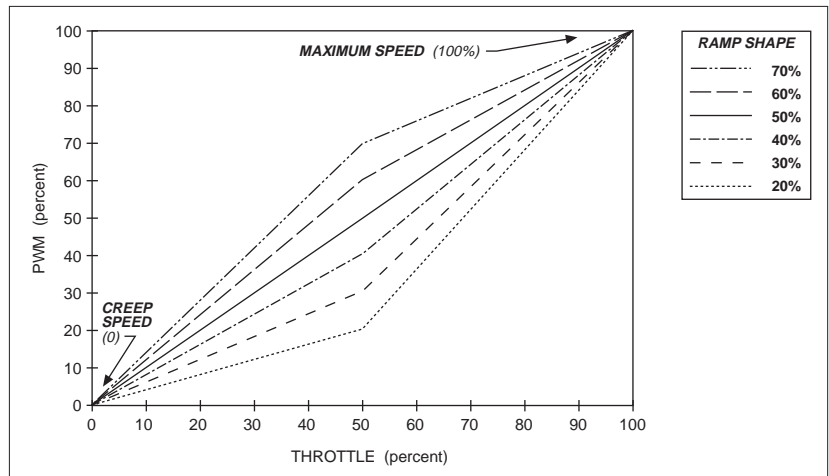

Changing either the maximum speed setting or the creep speed setting changes the output range of the controller. Ramp shape output is always a percentage of that range. Ramp shapes with the creep speed setting raised to 10% are shown in Figure A-2. In Figure A-3, the creep speed is kept at 10% and the maximum speed setting dropped to 60%.

**Fig. A-2** Ramp shape (throttle map) for controller with maximum speed set at 100% and creep speed set at 10%.

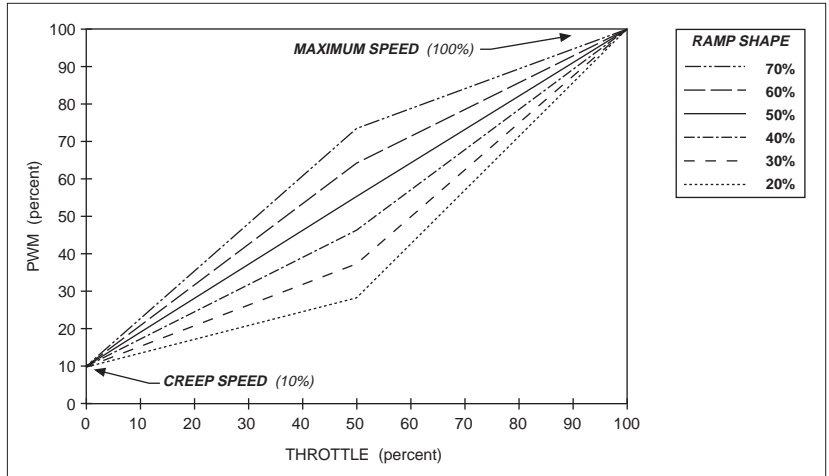

**Fig. A-3** Ramp shape (throttle map) for controller with maximum speed set at 60% and creep speed set at 10%.

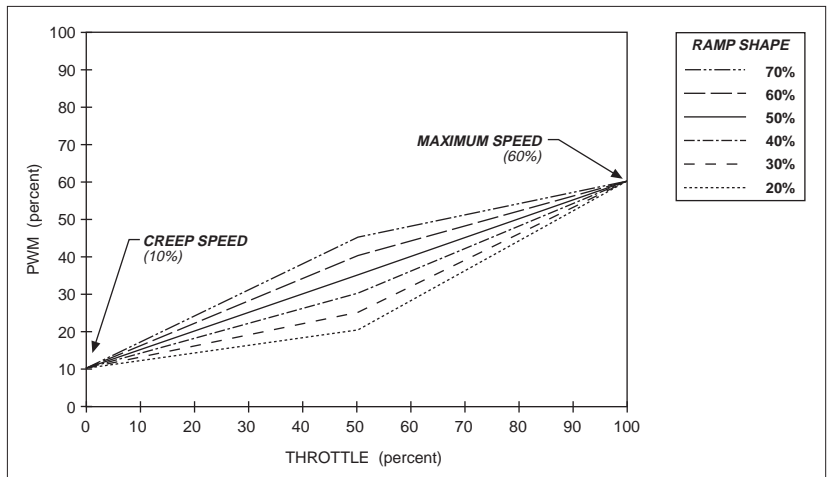

In all cases, the ramp shape number is the PWM output at half throttle, as a percentage of its full range. So, for example, in Figure A-3, a 50% ramp shape gives 35% PWM output at half throttle (halfway between 10% and 60%). A 30% ramp shape gives 25% PWM at half throttle (30% of the range {which is 50%, from 10% to 60%}, starting at 10% output, or  $\{[.30 \times 50] + 10\} = 25\%$ ).

## Ramp start (anti-rollback)

The ramp start feature allows the vehicle to be started with a higher plug current limit to prevent rolling downhill. Ramp start increases the plug current limit for the selected direction only. When the opposite direction is selected, ramp start will be canceled and a 3-step sequence must be followed to re-activate it:

- STEP 1. select a direction for more than 1 second
- STEP 2. return to neutral
- STEP 3. re-select the same direction.

Once the vehicle is operating in ramp start mode, it will continue to do so until the opposite direction is selected for more than one second. The new direction then becomes the decision direction, and the 3-step ramp start sequence is required to regain the ramp start current limit level.

The handheld programmer can be used to adjust the maximum ramp start current limit value. The instantaneous ramp start current limit when the brake is first released depends on throttle position and increases to the maximum programmed value as the throttle is increased.

## Reset

Almost all faults require a cycling of the KSI or brake/seat switch input to reset the controller and enable operation; see *“Fault recovery” for exceptions*.

## Sequencing delay

Sequencing delay allows the brake/seat switch to be momentarily opened within a set time (the sequencing delay), thus preventing inadvertent activation of HPD or SRO. This feature is useful in applications where the brake/seat switch may bounce or be momentarily cycled during operation. The delay can be set with the handheld programmer from 0 to 3 seconds, where 0 corresponds to no delay.

## Speed settings

The maximum speed setting defines the upper-limit speed as a percentage of PWM output at full throttle. The maximum speed settings in Mode 1 and in Mode 2 are independently adjustable via the handheld programmer.

The maximum creep speed setting (see *Creep speed*) and the maximum emergency reverse speed setting (see *Emergency reverse*) are also adjustable via the handheld programmer.

## Static-return-to-off (SRO)

The SRO feature prevents the vehicle from being started when “in gear.” SRO checks the sequencing of brake/seat switch input—or of KSI and brake input—relative to a direction input. The brake/seat switch input must come on before a direction is selected. If a direction is selected before or simultaneously (within 50 msec) with the brake input, the controller is disabled. There are three types of SRO: SRO relative to brake/seat switch input alone (Type “1” in the programming menu); SRO relative to brake/seat switch input plus KSI (Type “2”); and SRO relative to brake/seat switch input plus KSI plus forward only (Type “3”). The handheld programmer can be used to set the controller to operate with one of these types of SRO, or with no SRO (SRO Type “0”).

If your controller is wired so that both KSI and brake/seat switch input are required (SRO Type “2”), the following sequence must be followed to enable the controller: STEP 1, KSI on; STEP 2, brake/seat switch closed; and STEP 3, direction selected. The interval between steps 1 and 2 is the same as between steps 2 and 3; that is, KSI input must precede brake/seat switch input by at least 50 msec. Once the controller is operational, turning off either KSI or the brake/seat switch input causes the controller to turn off; re-enabling the controller requires the 3-step sequence.

Similarly, if your controller is wired so that KSI, brake/seat switch, and forward inputs are all required (SRO Type “3”), they must be provided in that sequence in order to enable the controller. However, operation is allowed if a reverse input precedes the brake/seat switch input; this can be useful when operating a walkie on ramps.

Sequencing delay, which can be set with the handheld programmer, provides a variable delay before disabling the controller. If the brake/seat switch is opened while direction is selected, SRO is not activated if the brake/seat switch is then closed before the delay time elapses.

## Temperature compensation for current limits

Full temperature compensation provides constant current limits throughout the normal operating range (heatsink temperatures of -25°C to +85°C). The temperature sensor is also used to calculate and display the heatsink temperature on the handheld programmer.

**Temperature extreme current-limit cutback** *(see Overtemperature, Undertemperature)*

## Temperature extreme data storage

The maximum and minimum temperatures read at the heatsink at any time during powering of the controller are stored in the controller's memory. These values (which can be accessed via the programmer's Test Menu) are cleared each time the controller's diagnostic history file is cleared. Each time the controller's power is cycled, the initially recorded maximum and minimum temperatures will be accurate only to within 10°C.

## Throttle map

The throttle map (duty factor as a function of throttle position) is adjustable, so that you can provide the proper feel for the many types of vehicles that use the 1214-/15-/19-8 controller. The throttle map parameter is called "ramp shape"; see the entry under *Ramp shape* for more information.

## Throttle response

The dynamic throttle response (duty factor as a function of time) is shaped by the acceleration rate setting. Dynamic throttle response is linear. The newest throttle input is mapped to the throttle map, and the controller then automatically accelerates (or decelerates) through a straight line until the new throttle demand is obtained.

## Throttle types

The 1214-/15-/19-8 controller accepts a variety of throttle inputs, through various combinations of its four throttle input pins. The most commonly used throttles (5k $\Omega$ -0 and 0-5k $\Omega$  pots, 3-wire pots, 0-5V, 0-10V, and the Curtis ET-XXX electronic throttle) can be hooked up simply by selecting the appropriate throttle type in the handheld programmer's Program Menu. Additional throttle types can also be accommodated; please contact the Curtis office nearest you.

Throttle full range produces 0-100% duty factor at the controller output (unless limited by other conditions). Throttle fault detect is performed on the throttle input signals and virtually eliminates the possibility of runaway operation. Adjustments and settings are independent of throttle type. However, throttle fault conditions will vary by throttle type.

## Undertemperature

When the controller is operating at less than  $-25^{\circ}\text{C}$ , the current limit is cut back to approximately one-half of the set current. The operating PWM frequency is shifted to 1.5 kHz when the controller is operating at undertemperature.

## Undervoltage protection

Undervoltage protection automatically disables the controller output if battery voltage is detected below the undervoltage point at start-up, or when the battery voltage is pulled below the undervoltage point by an external load. The undervoltage cutback point is set in ROM, and is not adjustable.

During normal operation, the controller duty factor will be reduced when the batteries discharge down to less than the undervoltage level. If the motor current is such that the batteries are being pulled below the minimum point, the duty factor will be reduced until the battery voltage recovers to the minimum level. In this way the controller “servos” the duty factor around the point which maintains the minimum allowed battery voltage.

If the voltage continues to drop below the undervoltage level to a severe undervoltage condition (due to battery drain or external load), the controller continues to behave in a predictable fashion, with its output disabled.

## Watchdog (external, internal)

The external watchdog timer guards against a complete failure of the microprocessor, which would incapacitate the internal watchdog timer. This independent system check on the microprocessor meets the EEC’s requirement for backup fault detection.

The external watchdog timer safety circuit shuts down the controller (and the microprocessor) if the software fails to generate a periodic external pulse train. This pulse train can only be created if the microprocessor is operating. If not periodically reset, the watchdog timer times out after 150 msec and turns off the controller. The external watchdog also directly disengages all contactors and directly shuts down the PWM drive to the MOSFETs. It can only be reset by cycling KSI.

The internal watchdog timer must be reset periodically by correct sequential execution of the software. If not reset, the internal timer times out and the microprocessor is “warm booted.” This causes the microprocessor to shut down its outputs (thus shutting down the controller) and attempt to restart.



## APPENDIX B

### SPECIFICATIONS

Nominal input voltage	24–36 V and 36–48 V
PWM operating frequency	15 kHz
Electrical isolation to heatsink	500 V ac (minimum)
Contactor voltage	= battery voltage
Contactor current (maximum)	1 amp [current limit at 2 amps]
Contactor coil spike protection	internal diode to brake; internal diode from brake to KSI
KSI input voltage	16–45 V
KSI input current (typical)	80 mA without programmer; 130 mA with programmer
Logic input current (typical)	10 mA at 24 V
Logic input threshold	8 V
Ambient operating temperature range	-40°C to 50°C
Heatsink overtemperature cutback	85°C
Heatsink undertemperature cutback	-25°C

	1214-8	1215-8	1219-8
Dimensions (L×W×H)	210 × 180 × 82 mm (8.3" × 7.1" × 3.2")	254 × 180 × 82 mm (10.0" × 7.1" × 3.2")	309 × 180 × 82 mm (12.2" × 7.1" × 3.2")

MODEL NUMBER	NOMINAL BATTERY VOLTAGE (volts)	CURRENT LIMIT (amps)	1 MIN RATING (amps)	2 MIN RATING (amps)	VOLTAGE DROP @ 100 AMPS (volts)	UNDER-VOLTAGE CUTBACK (volts)
1214-8XXX	24–36	400	—	400	<0.20	16
1214S-8XXX	24–36	500	500	—	<0.16	16
1215-8XXX	24–36	500	—	500	<0.16	16
1215S-8XXX	24–36	600	600	—	<0.14	16
1219-8XXX	24–36	600	—	600	<0.12	16
1219S-8XXX	24–36	700	700	—	<0.10	16
1219T-8XXX	24–36	800	800*	—	<0.08	16
1214-8XXX	36–48	350	—	350	<0.30	21
1215-8XXX	36–48	500	—	500	<0.20	21
1219-8XXX	36–48	600	—	600	<0.15	21

\* 30-second rating