



# CURTIS



## PUMP SYSTEM CONTROLLER

### MODEL 1254

**CURTIS INSTRUMENTS, INC.**  
200 KISCO AVENUE  
MT. KISCO, NY 10549  
USA  
TEL (914) 666-2971  
FAX (914) 666-2188

**CURTIS PMC**  
235 EAST AIRWAY BLVD.  
LIVERMORE, CA 94550  
USA  
TEL (925) 961-1088  
FAX (925) 961-1099

**CURTIS INSTRUMENTS, (UK) LTD.**  
5 UPPER PRIORY STREET  
NORTHAMPTON NN1 2PT, ENGLAND  
TEL 44 (0) 1604-629755  
FAX 44 (0) 1604-629876

**CURTIS INSTRUMENTS INDIA  
PRIVATE LTD.**  
DATTAPRASAD • AVANI APARTMENT  
APT. NO. 7 • 1206 B/7 APTE ROAD,  
SHIVAJI NAGAR • PUNE 411 004, INDIA  
TEL 91 (0) 20-5531288  
FAX 91 (0) 20-5539192

[www.curtisinst.com](http://www.curtisinst.com)

# PUMP SYSTEM CONTROLLER

## MODEL 1254

# CURTIS

### Application

The Curtis model 1254 Pump System Controller is ideal for material handling, industrial and man-up platform vehicles.

### DESCRIPTION

*Curtis Model 1254 Pump System Controller is specifically engineered to the unique characteristics of hydraulic motor and valve control.*

*Includes an advanced MOSFET power section and sophisticated microprocessor for high efficiency, silent operation, flexibility and ruggedness.*

### WARRANTY

Two Year Limited Warranty  
(see terms of sale for specifics)

### Features

#### Smooth Control of Hydraulic Functions

- Pulse-Width Modulation controlled pump motor provides smooth start-up and ramp-down on each function. Precise current and voltage control eliminates the bumps and jumps associated with on/off contactor control for increased efficiency and reduced contactor tip and motor brush wear.
- Load Compensation automatically varies the applied motor power in response to changes in weight and forces on the pump. Provides better speed regulation empty versus loaded, when picking up mast sections or while multiple functions are engaged.
- A current regulated proportional valve driver provides controlled, continuously variable speed lowering. An additional solenoid driver is provided for load hold or flow control.

#### Flexible and Programmable

- Up to 8 fixed speed and 3 variable speed inputs for maximum application flexibility. Speed control signals can be additive or prioritized in a myriad of combinations. An additional programmable feature permits a simple interface with a multi-function control handle.

### Features (continued)

- Fully compatible with all Curtis handheld and PC based programmers for testing, diagnostics and parameter adjustments.

#### Safety Features

- Meets or exceeds EEC fault detection requirements. Software and hardware circuitry detect faults in the variable speed controls and power section for safe operation.
- Power On Self Test and continuous diagnostics ensure proper operation. Dual watchdog circuits ensure software integrity.
- Programmable minimum speed setting for maintaining steering system pressure and pump lubrication.
- Lift interrupt/Inhibit input can be connected to a Curtis BDI or other interlock function to disable the controller at low battery or when the operator is not present.

#### Meets US and International Regulations

- The Curtis Model 1254 Controller is designed to meet:
  - EN 50081/2/08.93 for EMC emissions
  - EN 50082-2:1995 for EMC immunity
  - IEC 801-2 level 4 for ESD to 15kV
  - EN 1175-1:1998; VDE0117:1991; IEC 529 class IP64
  - UL Material Listing for flammability class 94V-0

#### Easy to Install and Maintain

- Simple wiring and installation with all signals referenced to battery positive. Low and high power connections are easy to reach and well spaced.
- An integral fault LED flashes helpful error code information. Two fault outputs provide diagnostic information for dash mounted displays. Faults are logged and the history is viewable through a Curtis Programmer.

### Options

- CAN Bus Communication port option allows control and access of all control and status functions through a standard two wire connection. Man-up vehicles can simplify wiring, improve reliability and reduce cost. Complex vehicles can connect multiple modules and share features and functions.
- Optional SepEx<sup>®</sup> (separately excited) pump control allows for increased performance under load. Top speed is better controlled and empty and loaded speeds are brought closer together.

## Model Chart

Model No.*	Voltage Rating (volts)	Current Rating 2 minutes (amps)	Current Rating 1 hour (amps)	Field Current Rating (SepEx <sup>®</sup> Models Only) 2 minutes (amps)
1254-44XX	24-36	400	160	40
1254-45XX	24-36	500	180	40
1254-46XX	24-36	600	200	40
1254-47XX	24-36	700	200	40
1254-54XX	36-48	400	150	40
1254-55XX	36-48	500	170	40
1254-56XX	36-48	600	190	40
1254-64XX	36-80	400	140	40
1254-65XX	36-80	500	160	40
1254-66XX	36-80	600	190	40

\*Series model designator shown. For other models replace "1254" designator as follows: Series = 1254 (shown)

SepEx = 1254X

Series CANbus = 1254C

SepEx CANbus = 1254CX

## Typical Wiring

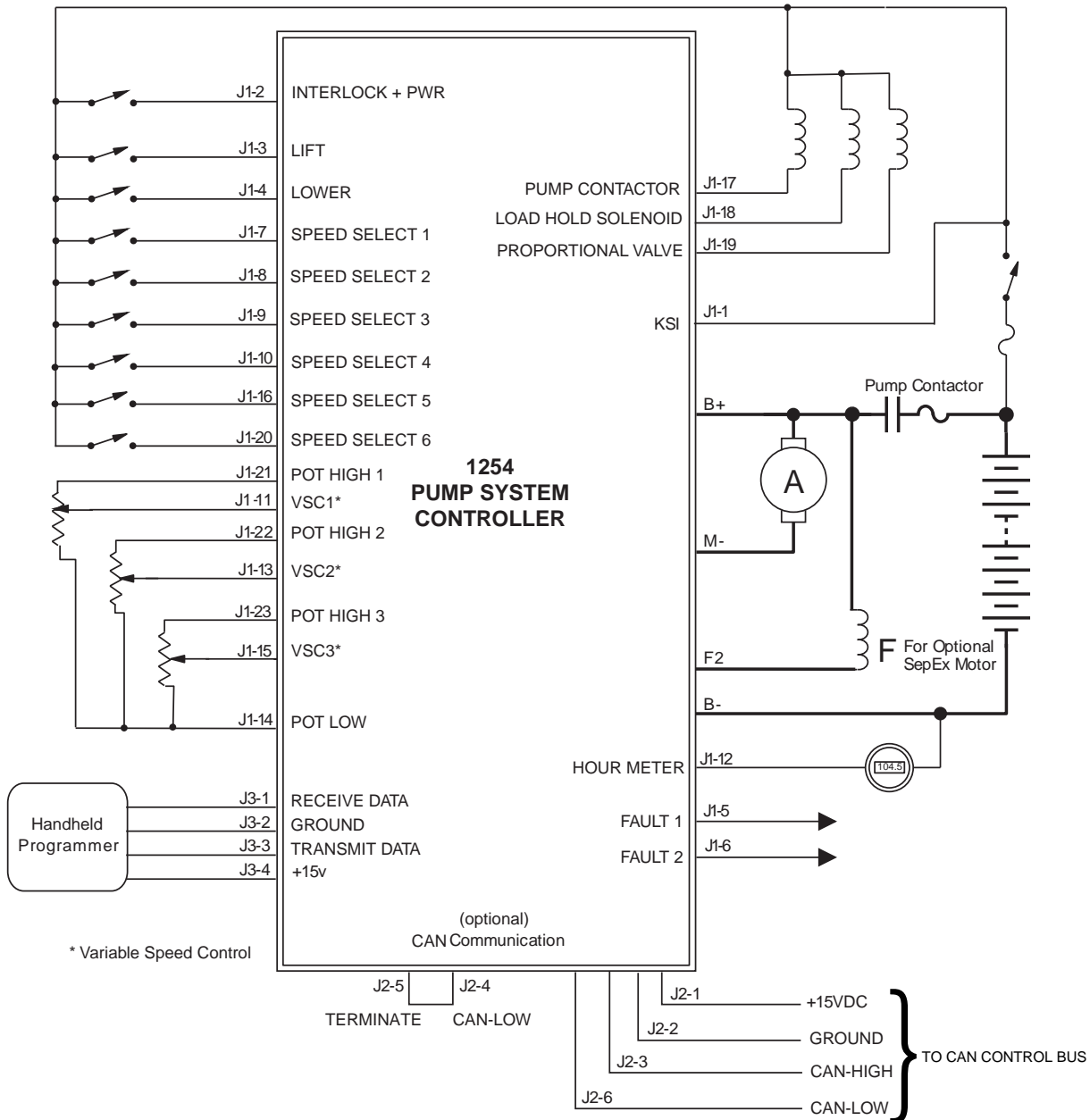

*Dimensions - mm (inches)*

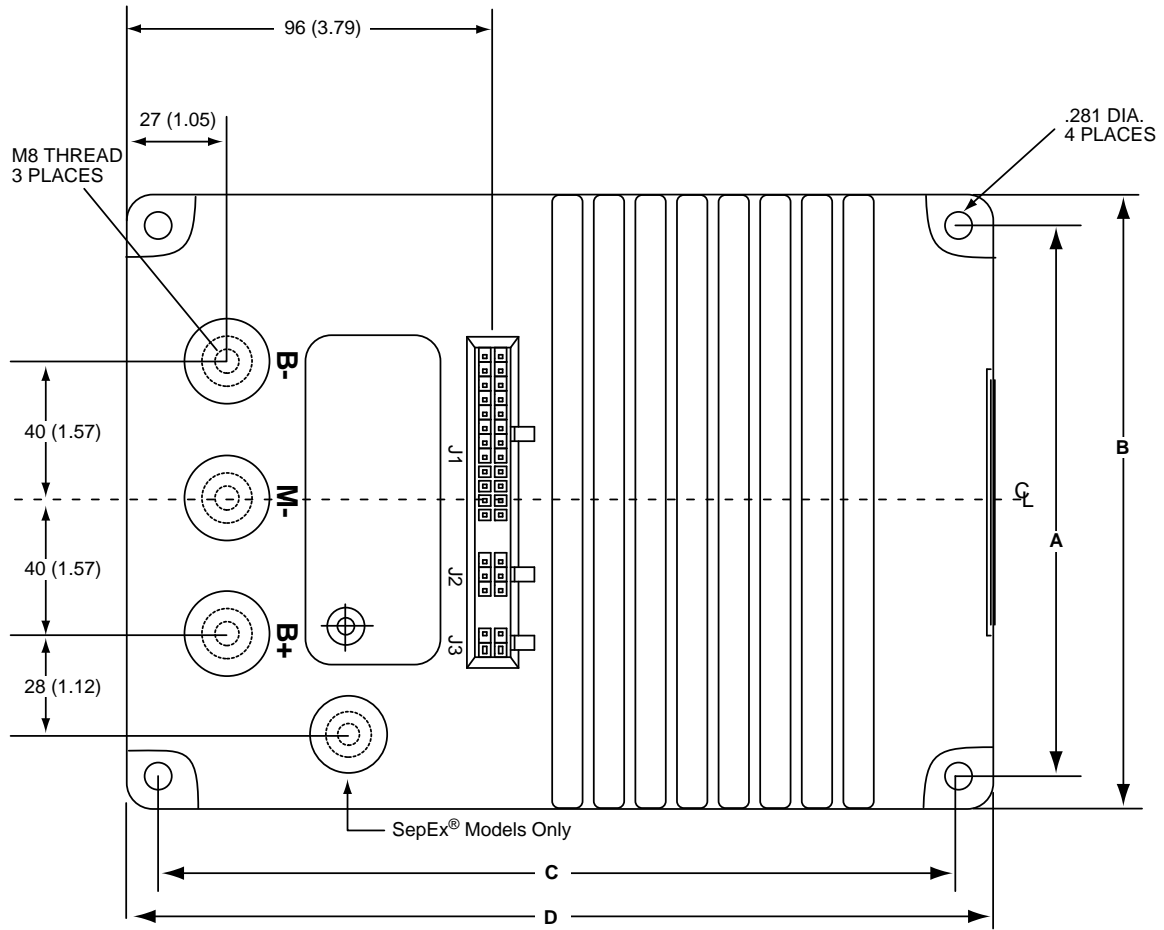

	A	B	C	D
1254	159 (6.25)	178 (7.00)	210 (8.25)	229 (9.00)

